

Volume and Surface Area of Parallelogram Prisms

1)

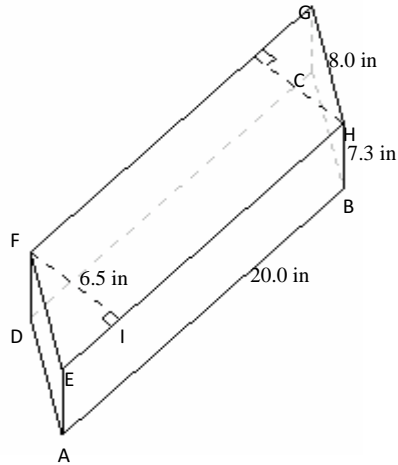

2)

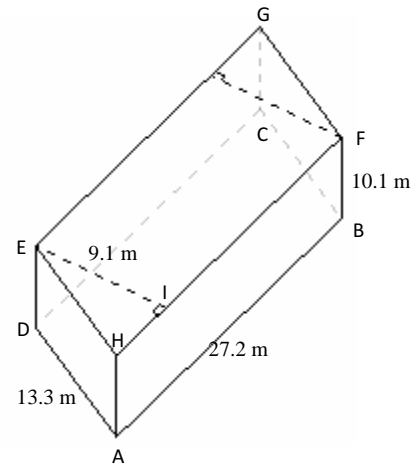

3)

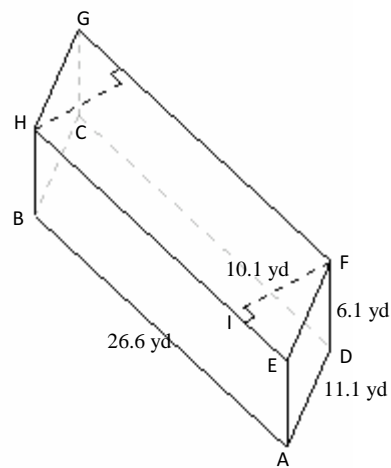

4)

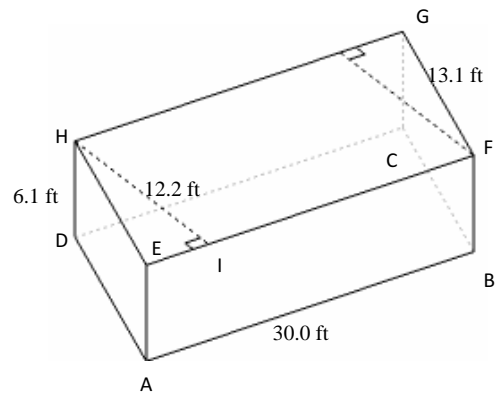

Volume and Surface Area of Parallelogram Prisms

Instructions: Find the volume and surface area for each parallelogram prism.

1)

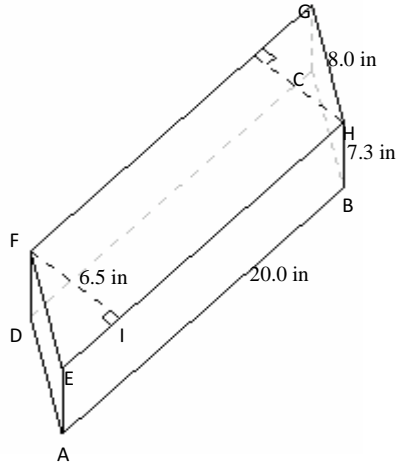

$$\begin{aligned} V &= \text{Area of } ABCD \times AE \\ &= (AB \times FI) \times AE \\ &= (20.0 \times 6.5) \times 7.3 \\ &= 949.0 \text{ in}^3 \end{aligned}$$

$$\begin{aligned} A &= (2 \times \text{Area of } ABCD) + (\text{perimeter of } ABCD \times AE) \\ &= (2 \times (AB \times FI)) + (((2 \times AB) + (2 \times BC)) \times AE) \\ &= (2 \times (20.0 \times 6.5)) + (((2 \times 20.0) + (2 \times 8.0)) \times 7.3) \\ &= 668.8 \text{ in}^2 \end{aligned}$$

2)

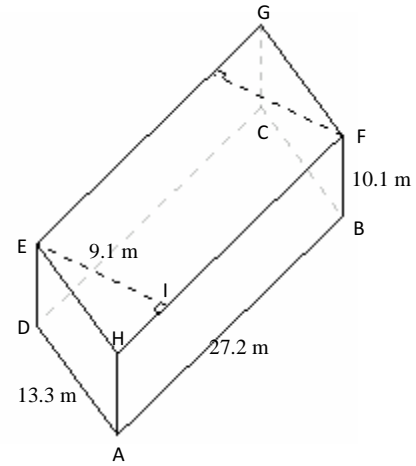

$$\begin{aligned} V &= \text{Area of } ABCD \times AE \\ &= (AB \times EI) \times FB \\ &= (27.2 \times 9.1) \times 10.1 \\ &= 2500.0 \text{ m}^3 \end{aligned}$$

$$\begin{aligned} A &= (2 \times \text{Area of } ABCD) + (\text{perimeter of } ABCD \times FB) \\ &= (2 \times (AB \times EI)) + (((2 \times AB) + (2 \times BC)) \times FB) \\ &= (2 \times (27.2 \times 9.1)) + (((2 \times 27.2) + (2 \times 13.3)) \times 10.1) \\ &= 1313.1 \text{ m}^2 \end{aligned}$$

3)

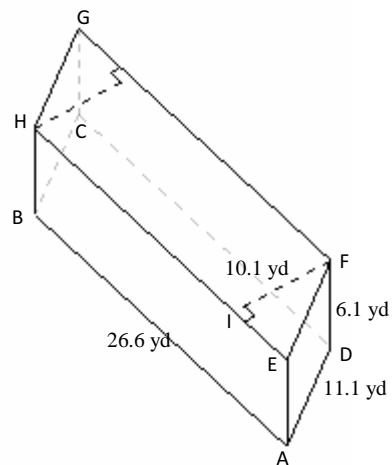

$$\begin{aligned} V &= \text{Area of } ABCD \times AE \\ &= (AB \times FI) \times AE \\ &= (26.6 \times 10.1) \times 6.1 \\ &= 1638.8 \text{ yd}^3 \end{aligned}$$

$$\begin{aligned} A &= (2 \times \text{Area of } ABCD) + (\text{perimeter of } ABCD \times AE) \\ &= (2 \times (AB \times FI)) + (((2 \times AB) + (2 \times BC)) \times AE) \\ &= (2 \times (26.6 \times 10.1)) + (((2 \times 26.6) + (2 \times 11.1)) \times 6.1) \\ &= 997.3 \text{ yd}^2 \end{aligned}$$

4)

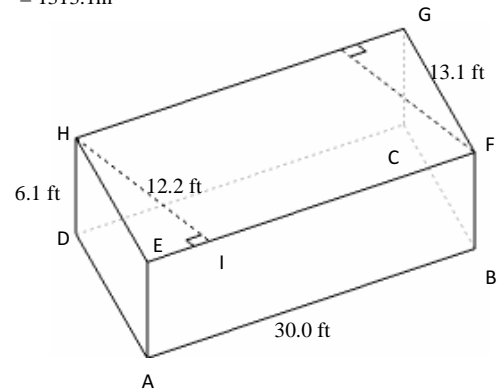

$$\begin{aligned} V &= \text{Area of } ABCD \times AE \\ &= (AB \times HI) \times HD \\ &= (30.0 \times 12.2) \times 6.1 \\ &= 2232.6 \text{ ft}^3 \end{aligned}$$

$$\begin{aligned} A &= (2 \times \text{Area of } ABCD) + (\text{perimeter of } ABCD \times AE) \\ &= (2 \times (AB \times HI)) + (((2 \times AB) + (2 \times BC)) \times HD) \\ &= (2 \times (30.0 \times 12.2)) + (((2 \times 30.0) + (2 \times 13.1)) \times 6.1) \\ &= 1257.8 \text{ ft}^2 \end{aligned}$$